

# Gene Flow Between Chromosomal Forms of the Malaria Vector *Anopheles funestus* in Cameroon, Central Africa, and Its Relevance in Malaria Fighting

Anna Cohuet,\* Ibrahima Dia,<sup>†</sup> Frédéric Simard,<sup>‡</sup> Michel Raymond,<sup>§</sup> François Rousset,<sup>§</sup>  
Christophe Antonio-Nkondjio,<sup>‡</sup> Parfait H. Awono-Ambene,<sup>‡</sup>  
Charles S. Wondji<sup>‡</sup> and Didier Fontenille\*<sup>1</sup>

\*Laboratoire de Lutte Contre les Insectes Nuisibles, Institut de Recherche pour le Développement, 34394 Montpellier Cedex 5, France,

<sup>†</sup>Laboratoire d'Entomologie Médicale, Institut Pasteur, Dakar, Senegal, <sup>‡</sup>Laboratoire d'Entomologie, antenne IRD,

Organisation de Coordination pour la lutte contre les Endémies en Afrique Centrale, Yaoundé,

Cameroon and <sup>§</sup>Institut des Sciences de l'Evolution, Laboratoire de Génétique et Environnement,

Université de Montpellier II, 34095 Montpellier, France

Manuscript received November 26, 2003

Accepted for publication June 29, 2004

## ABSTRACT

Knowledge of population structure in a major vector species is fundamental to an understanding of malaria epidemiology and becomes crucial in the context of genetic control strategies that are being developed. Despite its epidemiological importance, the major African malaria vector *Anopheles funestus* has received far less attention than members of the *Anopheles gambiae* complex. Previous chromosomal data have shown a high degree of structuring within populations from West Africa and have led to the characterization of two chromosomal forms, “Kiribina” and “Folonzo.” In Central Africa, few data were available. We thus undertook assessment of genetic structure of *An. funestus* populations from Cameroon using chromosomal inversions and microsatellite markers. Microsatellite markers revealed no particular departure from panmixia within each local population and a genetic structure consistent with isolation by distance. However, cytogenetic studies demonstrated high levels of chromosomal heterogeneity, both within and between populations. Distribution of chromosomal inversions was not random and a cline of frequency was observed, according to ecotypic conditions. Strong deficiency of heterokaryotypes was found in certain localities in the transition area, indicating a subdivision of *An. funestus* in chromosomal forms. *An. funestus* microsatellite genetic markers located within the breakpoints of inversions are not differentiated in populations, whereas in *An. gambiae* inversions can affect gene flow at marker loci. These results are relevant to strategies for control of malaria by introduction of transgenes into populations of vectors.

**M**ALARIA is a devastating disease killing >1.5 million people every year, mostly among African children under the age of 5 (WORLD HEALTH ORGANIZATION 1993). Although efficient means for control do exist, their implementation in African settings has so far remained ineffective and the burden of the disease is still increasing (GREENWOOD and MUTABINGWA 2002). Innovative strategies to combat malaria are thus needed. Plasmodium parasites, the causative agents of malaria, are transmitted from human to human through the bite of a mosquito vector that belongs to the genus *Anopheles*. Genetic control of wild vector populations to make them unable to transmit the parasite has therefore been proposed as a way to break down malaria transmission. The idea has gathered considerable research momentum during the past decades. Owing to recent development

in molecular entomology, bioinformatics, and genomics, this view is currently considered one of the most promising approaches to bring malaria transmission under control (JAMES *et al.* 1999; COLLINS *et al.* 2000; ALPHEY *et al.* 2002). Several important goals for the development of transgenic mosquitoes have indeed already been achieved, including germ-line transformation of *Anopheles* (CATTERUCCIA *et al.* 2000; GROSSMAN *et al.* 2001) and identification of several “candidate” genes involved in refractoriness of *Anopheles* to Plasmodium (SHAHABUDDIN *et al.* 1998; ITO *et al.* 2002; BLANDIN *et al.* 2004; OSTA *et al.* 2004). A number of genetic constructs are being considered as potential genetic drive systems that would facilitate the spread of effector genes into target vector populations and eventually lead to complete replacement of wild populations (KIDWELL and RIBEIRO 1992; RIBEIRO and KIDWELL 1994; TURELLI and HOFFMANN 1999; SINKINS and O’NEILL 2000). However, availability of these tools does not imply success of such a campaign. A comprehensive knowledge of the population genetic structure of the target species and of the forces that generate and maintain this structure

<sup>1</sup>Corresponding author: Laboratoire de Lutte Contre les Insectes Nuisibles, Institut de Recherche pour le Développement (LIN-IRD), 911 Ave. Agropolis, BP 64501, 34394 Montpellier Cedex 5, France.  
E-mail: didier.fontenille@mpl.ird.fr

is required to assess feasibility of this strategy, because the rate of gene flow in a subdivided population can be prohibitively slow (LANZARO and TRIPET 2003). Current vector control efforts involving insecticides will also benefit from knowledge of gene flow, which allows prediction of the spread of genes conferring insecticide resistance within and between natural vector populations.

To date, most population genetics studies targeting malaria vector species have focused on *Anopheles gambiae*, the major human malaria vector in sub-Saharan Africa, and demonstrated highly complex population genetic structure (DONNELLY *et al.* 2002; see TRIPET *et al.* 2004, accompanying article in this issue). However, a number of highly efficient malaria vectors occur in the field, but these have received far less attention than members of the *An. gambiae* complex, despite their epidemiological importance (FONTENILLE and SIMARD 2004). This is the case of the widespread *Anopheles funestus*, which has a high vectorial ability, sometimes higher than *An. gambiae* (FONTENILLE *et al.* 1997; MANGA *et al.* 1997). Vector control strategies must therefore also consider *An. funestus* as a main target species. In West Africa, *An. funestus* populations showed a high level of genetic and behavioral heterogeneity. Cytogenetic studies conducted in Burkina Faso and Senegal revealed highly significant departures from Hardy-Weinberg equilibrium for most chromosomal paracentric inversion systems and linkage disequilibrium between inversions located on different chromosomes, suggesting that *An. funestus* populations could be divided in chromosomal forms with low or no gene flow between them (LOCHOUARN *et al.* 1998; COSTANTINI *et al.* 1999; DIA *et al.* 2000a). Paracentric chromosomal inversions are known to reduce recombination between alternative arrangements (STURTEVANT and BEADLE 1936), especially at and close to the breakpoints (NAVARRO *et al.* 1997; ANDOLFATTO *et al.* 2001). As such, they are commonly viewed as adaptive mechanisms that can capture and stabilize blocks of coadapted genes with strong phenotypic effect, hence allowing ecological expansion in marginal habitats (MAYR 1963; DOBZHANSKY 1970). Ecological segregation of carriers of different inversion, coupled with strong genetic drift in isolated populations, could then lead to parallel segregation of mating recognition variants and speciation. A number of inversion-based speciation models have indeed been suggested (COLUZZI 1982; KING 1993; NOOR *et al.* 2001; REISEBERG 2001). Two chromosomal forms were defined for *An. funestus* in Burkina Faso: the first one, "Kiribina," was characterized by standard chromosomes or presence of inversion 2Rs; the second one, "Folonzo," was mainly polymorphic on chromosomal arm 2 and presented high frequencies of inversions 3Ra, 3Rb, and/or 3La (COSTANTINI *et al.* 1999; GUELBEOGO *et al.* 2002). In South and East Africa, however (namely, Angola and Kenya), chromosomal inversions were found polymorphic but, contrary to West Africa, heterokaryotypes were found at the ex-

pected Hardy-Weinberg frequencies in each location and no evidence for population subdivision was found (SHARAKHOV *et al.* 2001; BOCCOLINI *et al.* 2002; KAMAU *et al.* 2003). Thus, chromosomal structuring of wild *An. funestus* populations appears highly variable throughout Africa.

Very few data from Central Africa are available to date. A handful of populations from South Cameroon were analyzed for chromosomal inversion polymorphisms and fall within the definition of the Folonzo form, with additional inversions 2Rd and 2Rh that are commonly found in East Africa but absent from West African populations (DIA *et al.* 2000b). Taking advantage of the central geographic position of Cameroon in Africa, of the extreme diversity of ecological settings and widespread distribution of *An. funestus* throughout the country, we undertook a study of the genetic structure of the species by sampling *An. funestus* populations along a north-south transect in Cameroon representing a clear cline in aridity (Figure 1). Genetic diversity and population differentiation was assessed using cytogenetics (*i.e.*, chromosomal inversions distribution) and genotyping at 10 microsatellite markers that map both within and outside inversions (SHARAKHOV *et al.* 2004). This study design allowed us to explore the extent of genetic structuring within and between natural populations of this highly efficient malaria vector.

## MATERIALS AND METHODS

**Sampling sites:** Mosquitoes were collected across Cameroon along a transect from south to north: in Mfou (3°41' N, 11°32' E), Mbebe (4°19' N, 11°12' E), Ntui (4°26' N, 11°37' E), Nkoteng (4°30' N, 12°03' E), Foumban (5°47' N, 10°43' E), Bankim (6°20' N, 11°22' E), Tibati (6°28' N, 12°37' E), Ngaoundere (7°19' N, 13°35' E), Lagdo (9°30' N, 13°44' E), and Maga (10°51' N, 14°57' E) (Figure 1).

Humid forest in the south of the country gradually turns into arid savannas in the north. Cameroon can roughly be divided into four climatic zones, based on amount and distribution of annual rainfall (OLIVRY 1986). According to this classification, Mfou, Mbebe, Ntui, Fouban, and Bankim lie within the equatorial climate zone, with mean annual rainfalls ranging from 1600 to 1800 mm. In this area two rainy seasons occur: from March to June and from September to November. Tibati, Ngaoundere, and Maroua are located in the Sudanian climatic domain. Mean annual rainfall in this area decreases from south to north, with 1700 mm in Tibati and 900 mm in Lagdo. Only one rainy season occurs during the year, the number of rainy months decreasing from south to north. In Tibati the rainy season extends from March to November and in Lagdo from May to October. Maga is in the Sudano-Sahelian climate domain, with mean annual rainfalls ~750 mm and one rainy season from May to September.

**Mosquito collection and field processing of specimens:** Specimens were collected between October 2000 and January 2003 either after landing on human volunteers or by indoor pyrethrum spraying. Specimens from Mfou, Mbebe, and Nkoteng were collected during the rainy season in May 2001; specimens from Ngaoundere, Lagdo, and Maga were collected during the dry season in December 2001 and specimens from Ntui, Fouban, Bankim during the dry season in January

2003. Specimens from Tibati were collected during the rainy seasons of 2000 and 2002. Females from the *An. funestus* group were visually sorted from other anophelines according to morphological identification keys (GILLIES and DE MEILLON 1968; GILLIES and COETZEE 1987). All specimens were stored individually in tubes containing desiccant. Half-gravid females of the *An. funestus* group were dissected and ovaries, which contain polytene chromosomes on which chromosomal inversions can be scored, were immediately fixed in ice-cold Carnoy's fixative (one part of glacial acetic acid and three parts of pure ethanol). The corresponding carcasses were stored in tubes with desiccant. Back in the laboratory, all tubes were stored at  $-20^{\circ}$  until processed.

**DNA extraction and species identification:** Genomic DNA was extracted from wings and legs of each individual mosquito following a slightly modified version of the protocol of CORNEL and COLLINS (1996) and resuspended in sterile water. *An. funestus* s.s. females were included in the analysis after species identification was carried out by the recently described diagnostic PCR assay (KOEKEMOER *et al.* 2002; COHUET *et al.* 2003). No other member of the *An. funestus* group was observed in our samples.

**Microsatellite amplification:** Ten microsatellites loci were selected from published *An. funestus* sequence data (SINKINS *et al.* 2000; COHUET *et al.* 2002) on the basis of high polymorphism, apparent absence of null alleles, mean allele sizes ranging from 110 to 220 bp, and cytological location allowing whole-genome scan (Figure 2). We used AFND5 and FunO located on chromosomal arm 2R; FunL on chromosomal arm 2L; FunG, FunD, AFND19, and AFND20 on chromosomal arm 3R; FunF on chromosomal arm 3L; and AFND2 and AFND3, whose precise cytological location is still undefined (SHARAKHOV *et al.* 2004). PCR amplification was carried out in 25  $\mu$ l reaction volume of from 5 to 10 ng of template DNA. Reaction mixture contained 1 $\times$  PCR buffer containing 1.5 mM MgCl<sub>2</sub> (QIAGEN, Courtaboeuf, France), 200  $\mu$ M each dNTP, 10 pmol of each primer, and 0.5–1 unit Taq Polymerase (QIAGEN). The forward primer was labeled in 5' with TET, HEX, or FAM fluorescent markers (Eurogentec, Seraing, Belgium) to allow multiplex electrophoresis. Amplification was performed under the following conditions: an initial denaturation step at 94 $^{\circ}$  for 2 min followed by 36 cycles of 30 sec at 94 $^{\circ}$ , 30 sec at 54 $^{\circ}$ , 30 sec at 72 $^{\circ}$ , and a final elongation step of 10 min at 72 $^{\circ}$ . Fragment analyzes were conducted with an ABI PRISM 377. Alleles were sized relatively to an internal size standard using GENESCAN version 3.1 (Applied Biosystems, Foster City, CA).

**Polytene chromosome preparation:** Ovaries of half-gravid females were used to obtain squash preparations of the polytene chromosomes according to HUNT (1973). The preparations were examined under phase-contrast microscopy, and paracentric inversion karyotypes were scored according to the chromosomal map and nomenclature of SHARAKHOV *et al.* (2004).

**Data analysis:** For each microsatellite locus, deviation from Hardy-Weinberg expectations was tested in each location and overall. Cytogenetic data (*i.e.*, karyotypes) were analyzed in the same way, considering alternative chromosomal arrangements as different alleles at one locus as previously defined (LOCHOUARN *et al.* 1998; COSTANTINI *et al.* 1999; DIA *et al.* 2000a,b). Statistical significance was assessed by the exact probability tests available in GENEPOP 3.2 (RAYMOND and ROUSSET 1995). Statistical significance for linkage disequilibrium between pairs of microsatellite loci in the pooled population and within each population were computed by exact tests using GENEPOP 3.2. For specimens analyzed with both chromosomal and microsatellite markers, cytogenetic data were included in the analysis.

Genetic differentiation between geographical populations was examined by *F* statistic (WRIGHT 1951), calculated according to WEIR and COCKERHAM (1984). Significance of  $F_{ST}$  was assessed using the G-based exact test of genotypic differentiation (GOUDET *et al.* 1996). The correlation between genetic and geographical distances was assessed by the regression of  $F_{ST}/(1 - F_{ST})$  on the logarithm (ln) of geographical distance (ROUSSET 1997) and tested using the Mantel test available in GENEPOP.

Multilocus and/or multisample tests of deviations from Hardy-Weinberg equilibrium were done using Fisher's combination probabilities test using *P* values from each locus and/or population, as implemented in GENEPOP. Multilocus tests of population differentiation were conducted in the same way. The sequential Bonferroni procedure (HOLM 1979) can detect a single test-specific departure when multiple tests are performed: it was applied to evaluate significance of locus-specific departures within populations.

## RESULTS

**Chromosomal diversity and inversions distribution:** Cytological analysis was conducted in six villages: Ntui, Nkoteng, Bankim, Tibati, Ngaoundere, and Lagdo along the transect from south to north (Figure 1). All inversions found in Cameroon are schematized in Figure 2. No inversion was found on chromosomal arm 2L or on the X chromosome in accordance with former studies in this species. Polymorphism on chromosome arm 2R was low, with only three inversions observed (2R*a*, 2R*d*, and 2R*h*). As a result of extensive overlapping and apparent sharing of breakpoints among inversions 2R*a*, 2R*d*, and 2R*h*, these were never found to occur together on a single chromatid. We therefore treated them as different alleles of the same locus. Two independent inversions were observed on arm 3R (3R*a* and 3R*b*) and a single inversion was observed on arm 3L (3L*a*).

All three specimens karyotyped in Nkoteng were homozygous for inversions 3R*a*, 3R*b*, and 3L*a*. Inversions 2R*h* and 2R*d* were observed on arm 2R (Table 1). As 45 specimens previously analyzed in this village showed identical karyotypes, we could consider this population as fixed for inversions 3R*a*, 3R*b*, and 3L*a* and that two inversions, 2R*h* and 2R*d*, exist on arm 2R (DIA *et al.* 2000b). Inversions 2R*h* and 2R*d* were found in Nkoteng, Ntui, and Tibati. Inversion 2R*d* was always found at the heterozygote state with inversion 2R*h* as previously recorded in this region (DIA *et al.* 2000b). Inversion 2R*a* was observed in only two sampling sites (Ntui and Bankim). The frequency of the standard (2R+) arrangement increased in northern populations and was fixed beyond Ngaoundere. Inversions 3R*a* and 3R*b* were fixed in Nkoteng and absent in Lagdo where only the standard (3R+) arrangement was found. Clinal frequencies were found in localities in between. Inversion 3L*a* was fixed in Ntui and Nkoteng and its frequency decreased in northern populations until becoming rare in Lagdo. Clinal distribution of chromosomal inversions was therefore observed on chromosomal arms 2R, 3R, and 3L, with inversions being more represented in villages from

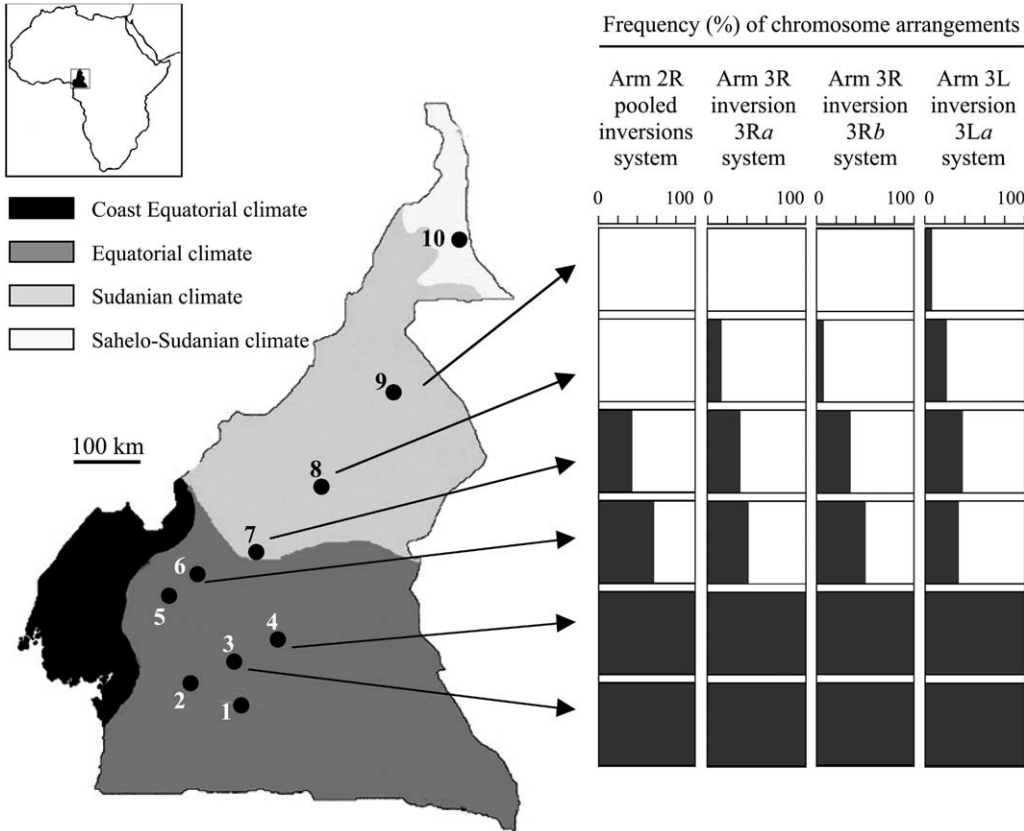

FIGURE 1.—Geographical position of Cameroon (inset). Localities sampled for *An. funestus* across Cameroon and clinal distribution of chromosomal inversions: 1, Mfou; 2, Mbebe; 3, Ntui; 4, Nkoteng; 5, Foumban; 6, Bankim; 7, Tibati; 8, Ngaoundere; 9, Lagdo; 10, Maga. (Right) Solid areas represent inverted arrangements, and open areas represent standard arrangements.

forested areas and standard arrangements more frequently found in drier savannas, with a gradient of frequencies along the latitudinal transect (Figure 1).

When considering all karyotyped specimens as belonging to a single population, Hardy-Weinberg equilibrium was significantly rejected ( $P < 10^{-4}$ ) for all chromosomal inversions with a deficit of heterozygotes (Table 1, “Pooled”). All pairs of chromosomal inversions were in linkage disequilibrium (Table 2).

Following COSTANTINI *et al.* (1999), all specimens from Nkoteng and Ntui belong to the Folonzo form while all those from Lagdo belong to Kiribina. Both

chromosomal forms were found in Bankim, Tibati, and Ngaoundere, within the transitional zone between forest and savannas. In Tibati, where sample size was appropriate for subsequent analysis, significant departure from Hardy-Weinberg equilibrium was observed for all inversions due to a deficit of heterokaryotypes (Table 1). Hardy-Weinberg equilibrium was reestablished when individuals were assigned to chromosomal forms using the set of rules proposed by COSTANTINI *et al.* (1999). Linkage disequilibrium between all pairs of inversions was highly significant ( $P < 0.01$ ) in Tibati: 2Rd, 2Rh, 3Ra, 3Rb, and 3La were almost always associated all together while arrangements 2R+, 3R+, and 3L+ occurred together in the same individuals, despite the fact that arms 2R and 3R are on two different chromosomes. This is consistent with a genetic subdivision of *An. funestus* populations in distinct chromosomal forms in this location. In Ngaoundere a similar pattern was observed, but  $F_{IS}$  values were not statistically significant, probably because of low sample size in this locality. In contrast, in Bankim, Hardy-Weinberg expectations were not rejected, except for the inversion system on chromosomal arm 3L, and no linkage disequilibrium was significant between inversions.

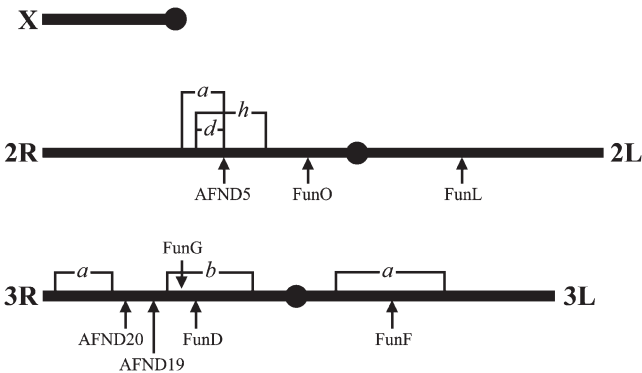

FIGURE 2.—Chromosomal inversions of *An. funestus* in Cameroon and location of microsatellites loci (SHARAKHOV *et al.* 2004).

**Microsatellite diversity and neutral population structure:** Genotypes at 10 microsatellite loci were determined for all karyotyped and additional *An. funestus* specimens. In total, 583 adult females, collected in 10 villages spread along a south-north transect in Camer-

TABLE 1

Inversion frequencies and significance level for goodness-of-fit tests to Hardy-Weinberg equilibrium for chromosomal inversions within *An. funestus* populations from Cameroon

Inversion systems	Populations						
	Ntui	Nkoteng	Bankim	Tibati	Ngaoundere	Lagdo	Pooled <sup>a</sup>
<b>2Rdha</b>							
2n	12	6	14	46	10	40	128
f(+)	0	0	0.43	0.65	1.00	1.00	0.67
f(h)	0.25	0.50	0	0.26	0	0	0.14
f(d)	0.25	0.50	0	0.09	0	0	0.08
f(a)	0.50	0	0.57	0	0	0	0.11
F <sub>IS</sub>	0.29*	-1	-0.09	0.66**	—	—	0.58**
<b>3Ra</b>							
2n	12	6	24	54	14	46	156
f(+)	0	0	0.58	0.67	0.86	1.00	0.69
f(a)	1.00	1.00	0.42	0.33	0.14	0	0.31
F <sub>IS</sub>	—	—	0.01	0.84**	0.63	—	0.74**
<b>3Rb</b>							
2n	12	6	24	52	14	44	152
f(+)	0	0	0.50	0.65	0.93	1.00	0.68
f(b)	1.00	1.00	0.50	0.35	0.07	0	0.32
F <sub>IS</sub>	—	—	-0.29	0.67**	—	—	0.61**
<b>3La</b>							
2n	12	6	18	56	14	46	152
f(+)	0	0	0.67	0.63	0.79	0.93	0.66
f(a)	1.00	1.00	0.33	0.37	0.21	0.07	0.34
F <sub>IS</sub>	—	—	1**	0.61**	0.63	-0.05	0.74**

F<sub>IS</sub> was calculated according to WEIR and COCKERHAM (1984). 2n, number of chromatids scored. \*P < 0.05; \*\*P < 0.05 after Bonferroni correction (see text). —, sample size too low to warrant analyzes or only one arrangement found.

<sup>a</sup> All specimens were considered as belonging to one single panmictic population.

oon (Figure 1), were analyzed. Four microsatellites loci mapped within polymorphic chromosomal inversions: AF5 in 2Rd, 2Rh, and 2Ra, FunD and FunG in 3Rb, and FunF in 3La. Four other loci, FunO, FunL, AFND20, and AFND19, were located outside chromosomal inversions (Figure 2), while the precise cytological location of AF2 and AF3 is still unknown (SHARAKHOV *et al.* 2004). All loci were highly polymorphic, showing between 8 and 32 alleles per locus. Similar levels of variability were observed in all populations with a mean number of alleles per locus ranging from 10.3 to 11.6 and average observed heterozygosity across all loci ranging from 0.72 to 0.81.

At the population level, slight deviations from Hardy-Weinberg expectations occurred. They remained significant in three cases after the sequential Bonferroni procedure was applied over loci and populations (locus AFND2 in the population of Ngaoundere and Maga, locus FunD in Fouban). The Hardy-Weinberg disequilibrium across all loci remained significant only in one population, Fouban, and was due to one locus (FunD; Table 3). Thus, no major departure from Hardy-Weinberg equilibrium was evident in any population and in particular none matched the deficiency of heterokaryo-

types in Tibati. Exact tests for linkage disequilibrium within each population (450 pairwise comparisons) resulted in four significant values after correction by the sequential Bonferroni procedure, each in different populations. Several loci are relatively close to one another in the genome (AF20, AF19, FunD, and FunG on arm 3R; see Figure 2); however, our results suggest absence of statistical linkage. Together with Hardy-Weinberg equilibrium, linkage disequilibrium analysis revealed that each geographical population, including Tibati, might be considered as panmictic.

Linkage disequilibrium between microsatellite loci and chromosomal inversion systems was assessed considering only specimens for which both microsatellite genotype and karyotype was known (78 individuals). Among 40 pairwise linkage disequilibrium tests, 3 were significant (P < 0.05) at the single test level. None of them remained significant after application of the Bonferroni correction, showing no association between chromosomal inversions and microsatellite alleles (Table 2).

Pairwise F<sub>ST</sub> estimates between populations and across all loci are shown in Table 4, together with corresponding geographical distance between sampling sites. Aver-

**TABLE 2**  
**Pairwise linkage disequilibrium for 10 microsatellite loci and four chromosomal inversions for pooled *An. f. finestus* populations**

	Microsatellite loci										Chromosomal inversions			
	Within inversions					Outside inversions					Not located			
	AFND5	FunG	FunD	FunF	FunO	AFND20	AFND19	FunL	AFND2	AFND3	2Rdha	3Ra	3Rb	3La
Microsatellite loci														
Inside inversions														
AFND5	-													
FunG		+												
FunD			+											
FunF				+										
Outside inversions														
FunO	+	+ <sup>a</sup>	+	+										
AFND20	-	-	+	-	-									
AFND19	-	-	-	-	+	+								
FunL	-	+ <sup>a</sup>	-	-	+ <sup>a</sup>	-								
Not located														
AFND2	-	-	-	+	-	-		+						
AFND3	-	-	-	-	-	-		+	-					
Chromosomal inversions														
2Rdha	-	-	-	-	-	-		-	+					
3Ra	-	-	-	-	-	-		-	-				+	+
3Rb	-	-	-	-	-	-		-	-				+	+
3La	+	-	-	+	-	-		-	-				+	+

+ , significant ( $P < 0.05$ ) linkage disequilibrium before Bonferroni procedure; -, lack of significance ( $P < 0.05$  level).

<sup>a</sup> Significant ( $P < 0.05$ ) linkage disequilibrium after Bonferroni procedure.

TABLE 3  
 Estimate of  $F_{IS}$  and significance level for goodness-of-fit tests to Hardy-Weinberg equilibrium for 10 microsatellite loci within *An. funestus* populations from 10 localities in Cameroon

Locus	Populations										Pooled <sup>a</sup> (2n = 1166)
	Mfou (2n = 108)	Mbebe (2n = 112)	Ntui (2n = 104)	Nkoteng (2n = 112)	Foumban (2n = 96)	Bankim (2n = 96)	Tibati (2n = 176)	Ngaoundere (2n = 108)	Lagdo (2n = 146)	Maga (2n = 108)	
AFND2	-0.044	0.016	-0.022	0.061	0.017	0.028	0.043*	0.115**	-0.050*	0.111**	0.061**
AFND3	-0.025	0.004	0.241	-0.049	-0.011	-0.081	-0.148	-0.244	0.186	-0.074*	-0.024*
AFND5	0.059	0.031	0.068	-0.170	-0.114	-0.265	-0.075	0.133	-0.029	-0.033	-0.035
FunO	0.066	0.111	0.151	0.116	0.068	-0.043*	-0.015	0.003	-0.023*	0.008	0.049*
AFND20	0.168*	0.224*	-0.011	0.061	0.055	0.104	0.131*	0.076	0.016	0.128	0.097**
AFND19	0.099	0.013	0.030	-0.021	-0.068*	-0.023	0.039	-0.062	0.146*	-0.028	0.029*
FunG	0.030	-0.009	0.130	0.041	-0.032	-0.038	-0.063	-0.122	-0.085	0.020	0.000
FunD	0.089	0.000	0.065	-0.005	0.078**	-0.005	-0.009	0.058*	-0.007	0.042	0.051**
FunL	0.036	0.003	-0.045	-0.010	0.080	0.070	0.108	0.008	-0.049	0.050	0.029
FunF	-0.035	-0.005	-0.112	-0.012	0.200	0.020	-0.022	-0.072	-0.022	-0.068	-0.003
Mean across all loci <sup>b</sup>	0.044	0.039	0.050	0.012	0.027*	-0.016*	-0.010	-0.011*	0.009*	0.016	0.025*

$F_{IS}$  was calculated according to WEIR and COCKERHAM (1984). 2n, number of chromosomes scored. \* $P < 0.05$ ; \*\* $P < 0.05$  after Bonferroni correction (see text).

<sup>a</sup> All specimens were considered as belonging to one single panmictic population.

<sup>b</sup> Multilocus  $F_{IS}$  estimates were computed according to WEIR and COCKERHAM (1984) using GENEPOP 3.2. (RAYMOND and ROUSSET 1995); statistical significance of  $F_{IS}$  across loci was assessed through Fisher's exact test.

TABLE 4

Measure of genetic differentiation ( $F_{ST}$ ) and geographical distance among *An. funestus* populations from Cameroon

	Mfou	Mbebe	Ntui	Nkoteng	Foumban	Bankim	Tibati	Ngaoundere	Lagdo	Maga
Mfou	—	80	85	105	250	270	330	460	640	880
Mbebe	0.0062*	—	50	100	170	190	290	420	580	830
Ntui	0.0083*	0.0071	—	50	195	175	250	380	560	800
Nkoteng	-0.0002	-0.0022	0.0037	—	190	180	230	380	550	800
Foumban	0.0164*	0.0289*	0.0184*	0.0203*	—	80	220	360	490	740
Bankim	0.0107*	0.0137*	0.0026	0.0090*	0.0095*	—	130	260	410	660
Tibati	0.0203*	0.0293*	0.0123*	0.0199*	0.0079*	0.0044*	—	150	310	540
Ngaoundere	0.0330*	0.0386*	0.0165*	0.0298*	0.0231*	0.0113*	0.0046*	—	190	410
Lagdo	0.0281*	0.0368*	0.0146*	0.0250*	0.0315*	0.0136*	0.0108*	0.0112	—	240
Maga	0.0298*	0.0373*	0.0145*	0.0283*	0.0224*	0.0102*	0.0028*	0.0015	0.0067*	—

$F_{ST}$  is below the diagonal. Distance in kilometers is above the diagonal. \* $P < 0.01$ .

age  $F_{ST}$  based on the whole data set (10 loci and 10 populations) was low (0.0145) but highly significant ( $P < 10^{-4}$ , by Fisher's combined probability test), suggesting restricted gene flow between *An. funestus* populations at this geographical scale. All loci, except AFND3 and AFND20, showed significant genetic differentiation ( $P < 0.05$ ), with  $F_{ST}$  estimates ranging from 0.0014 to 0.0375. Genome-wide differentiation was therefore demonstrated. Heterogeneity of the gene pool was further confirmed by global analysis of all samples. Hardy-Weinberg predictions were significantly rejected ( $P < 0.05$ , single test level) for 6 loci, with positive values of  $F_{IS}$  for 5 of them (Table 3, "Pooled") and linkage disequilibrium between loci was detected in 14 of 45 tests ( $P < 0.05$ , single test), 3 of them remaining significant after Bonferroni procedure was applied (Table 2).

Mean  $F_{ST}$  estimates were computed separately for loci within (AFND5, 0.0066; FunG, 0.0212; FunD, 0.0267; FunF, 0.0090) and outside (FunO, 0.0169; AFND20, 0.0018; AFND19, 0.0150; FunL, 0.0014) chromosomal inversions. Comparison by Mann-Whitney test was non-significant ( $P > 0.05$ ) but power was clearly low, which suggests homogeneity among these groups of loci and

negligible (if any) influence of chromosomal inversions on our estimates.

Isolation by distance was tested and statistically significant correlation between genetic (pairwise  $F_{ST}$ ) and geographic distance ( $P < 10^{-4}$ ) was detected when considering the whole data set (Figure 3). These results suggest that the level of genetic differentiation between populations of *An. funestus* in Cameroon is due to a decrease of gene flow by geographical distance. To investigate whether one or few loci were responsible for the significant results, we repeated the analysis by keeping, in a stepwise procedure, all data except for one locus. Then we considered only loci located within chromosomal inversions or only loci located outside inversions. The results remained significant regardless of which locus was removed or which group of loci was considered ( $P < 0.05$ ). These data suggest that isolation by distance is due to the whole set of loci.

## DISCUSSION

**Adaptive role of chromosomal inversions:** In *An. funestus* populations from Cameroon, chromosomal inversions were distributed along a cline of frequencies. Similar clines in frequencies of chromosomal inversions associated with an environmental gradient were previously observed in other Diptera. In the *Drosophila* genus, paracentric inversions are almost ubiquitous and their distribution was found to correlate with contrasting environmental conditions (ANDERSON 1989; KRIMBAS and POWELL 2000). Such a distribution was explained by the fact that chromosomal inversions would be maintained through directional selection pressure. In African malaria vectors, the biological significance of inversion polymorphism has been studied in depth in two species of the *An. gambiae* complex, namely *An. gambiae* s.s. and *An. arabiensis*. Chromosomal inversions were also found to be distributed according to ecotypic conditions (COLUZZI *et al.* 1979, 1985; COLUZZI 1982; TOURE *et al.* 1998; PETRARCA *et al.* 2000) and are supposed to be strongly exposed to

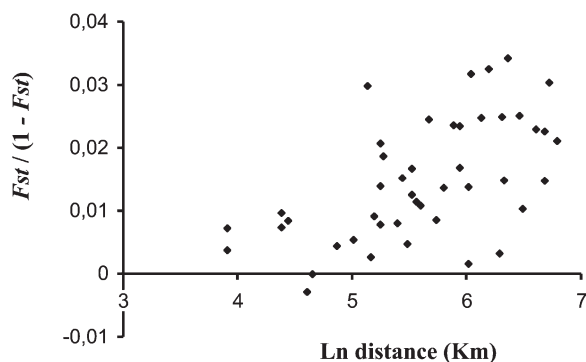

FIGURE 3.—Correlation between  $F_{ST}/(1 - F_{ST})$  and logarithm of distance (in kilometers) for pairwise comparisons of 10 *An. funestus* populations from Cameroon at the 10 microsatellite loci analyzed.



environmental selection (COLUZZI *et al.* 1979). In *An. funestus* populations from Cameroon, the clines of frequencies of chromosomal inversions along the transect, together with strong linkage disequilibrium between inversions located on distinct chromosomes, are therefore in agreement with a similar adaptive role of inversions: 2R*d*, 2R*h*, 2R*a*, 3R*a*, 3R*b*, and 3L*a* would favor adaptation to moist equatorial climates, while standard arrangements would confer a better adaptive value under drier conditions.

**The taxonomic status of chromosomal forms in *An. funestus*—reconciling microsatellite and chromosomal data:** According to the speciation hypothesis proposed by COSTANTINI *et al.* (1999), both Folonzo and Kiribina chromosomal forms are considered isolated reproductive units, each one having its own set of chromosomal inversions. Thus, although certain chromosomal inversions may be shared between them, others might have diagnostic values and could be considered as specific to one or the other of these forms. This is the case, for example, between *An. gambiae* and *An. arabiensis*, both established species being characterized by fixed inversions on chromosome X, and with inversion 2L*a* fixed in *An. arabiensis* and polymorphic in *An. gambiae* (TOURE *et al.* 1998; COLUZZI *et al.* 2002). In this case, evidence for genetic divergence between species/populations should be found throughout the genome, the amplitude of which will depend on time since lineage splitting. High amounts of genetic differentiation were indeed revealed between *An. gambiae* and *An. arabiensis* using, among others, microsatellite markers (KAMAU *et al.* 1998; LANZARO *et al.* 1998; WANG *et al.* 2001; BESANSKY *et al.* 2003). Our data are in poor agreement with this hypothesis in *An. funestus*.

In the forest-savanna transition area where chromosomal inversions were polymorphic, we found two contrasting patterns. In Tibati, chromosomal structuring suggested local subdivision of *An. funestus* in chromosomal forms. This is reminiscent of the situation in West Africa, which led to characterization of the Folonzo and Kiribina forms (LOCHOUARN *et al.* 1998; COSTANTINI *et al.* 1999; DIA *et al.* 2000a). In Bankim, however, panmixia was not rejected. The same situation was formerly observed in Angola (BOCCOLINI *et al.* 2002), Kenya (SHARAKHOV *et al.* 2001; KAMAU *et al.* 2003), and Madagascar (G. LE GOFF, personal communication), thus underlining that the subdivision in chromosomal forms could not be generalized to the whole species range.

Microsatellite markers showed no departure from panmixia in any geographical population from Cameroon. Microsatellite loci located within polymorphic chromosomal inversions, as well as loci located outside, detected isolation by distance between geographical isolates, thus providing support for the usefulness of microsatellite markers to detect population substructure in *An. funestus* and negligible, if any, effect of allele size homoplasy. Recombination between inverted chromo-

somal regions might occur in heterozygous individuals through multiple crossing over or gene conversion. Although such a phenomenon is expected to occur at low frequency, it has been shown that recombination rate and gene flow are highly site dependent inside inverted regions: they are maximal in the central region of the inversion and minimal at the breakpoints (NAVARRO *et al.* 1997; ANDOLFATTO *et al.* 2001). They also depend on the length of the inversions and on the species studied (CACERES *et al.* 1999). It is therefore likely that the regions examined by our microsatellite markers are not the most affected by the reduction of recombination, even if some of them are close to the breakpoints (*i.e.*, FunG and AFND5). High-resolution mapping using additional microsatellite and/or single nucleotide polymorphism markers should help pinpoint chromosomal regions, as well as the genes they contain, that are most exposed to environmental selection and potentially involved in ecotypic adaptation.

Altogether, our results are inconsistent with complete reproductive isolation between chromosomal forms. The conundrum in our data is that inversion heterozygotes apparently are inviable or do not occur frequently, and yet there is no allelic differentiation of markers found within inversions. The apparent homogeneity of the gene pool might result from historical rather than current gene flow between chromosomal forms. This is an issue that warrants further investigation.

**Inversion heterozygote deficiency:** Positive assortative mating, *i.e.*, the general trend for like inversions to mate together more often than expected if mating is random, could explain the excess of homozygous karyotypes observed within *An. funestus* populations. Assortative mating could be due to mate choice favoring mating between individuals belonging to the same chromosomal form, or chromosomal forms could be separated temporally or spatially at the microgeographic scale (*i.e.*, parapatry) at the time mating occurs, although sympatry is observed at the adult stage when sampling blood-seeking or resting females. However, this hypothesis cannot explain the pattern observed at the continental scale, with an inversion subdivision of *An. funestus* populations in West Africa while chromosomal inversions reveal no heterokaryotype deficit in South and East Africa.

Another hypothesis that fits better with the pattern of observed data involves selection acting against hybrid heterokaryotypes. *An. funestus* chromosomal forms may freely interbreed in nature, but strong underdominance due to environmental selection against hybrid heterokaryotypes would limit their development. As we found both chromosomal forms to be represented at the adult stage when sampling blood-seeking and resting females, we assume that differential environmental adaptation between chromosomal forms would play a role at earlier stages. Selection pressure on chromosomal inversions could therefore occur at the larval stage, with different types of breeding sites being preferred by each chromo-

somal form as observed in *An. gambiae* (COLUZZI *et al.* 1985, 2002; TOURE *et al.* 1998).

Our study does not support the hypothesis of complete reproductive isolation between chromosomal forms in *An. funestus* populations from Cameroon and we favor the effect of negative environmental selection to explain the lack of hybrid heterokaryotypes in the face of genetic homogeneity revealed by microsatellite (possibly neutral) markers. As previously found in *An. gambiae* s.s. (DELLA TORRE *et al.* 2001, 2002), we emphasize the role of chromosomal inversions in ecological adaptation and the lack of concordance between chromosomal forms and reproductive units. However, the causes of inversion heterozygote deficiency are still unclear and further studies are needed.

**The control of malaria in Africa:** Our study deals with one of the most efficient human malaria vectors in the world, which despite its epidemiological importance in malaria transmission (GILLIES and DE MEILLON 1968) has been widely overlooked by the scientific community. This may be partially attributed to the fact that *An. funestus* is much harder to breed in the laboratory than *An. gambiae*, thereby hindering classical genetic mapping and transformation experiments. However, if the ultimate goal of studies of malaria vectors is to eventually achieve control of the disease in the field, this deficiency is not acceptable. Any population genetic control measure to be implemented, such as autocidal control (see GOULD and SCHLIEKELMAN 2004) or introduction of transgenes for Plasmodium resistance, needs to account for the presence in the field of numerous vector species and populations among which gene flow appears to be restricted or not. In the case of *An. gambiae*, gene flow has been observed to be restricted by inversion (TRIPET *et al.* 2004), but in the case of *An. funestus* in Cameroon, inversions do not restrict gene flow. Thus, inversions could interfere with the spread of transgenes in *An. gambiae*, but appear to be less of a concern for *An. funestus* whenever transformation is available for this species. The success of any strategy for malaria control in Africa through genetic modification of its mosquito vectors will rely on our ability to target all the species and populations that significantly contribute to the transmission and will require a thorough understanding of the relevant population genetics.

We acknowledge the villagers for their cooperation throughout the survey. This study was funded by the French ministry of research throughout the PAL+ project.

#### LITERATURE CITED

- ALPHEY, L., C. B. BEARD, P. BILLINGSLEY, M. COETZEE, A. CRISANTI *et al.*, 2002 Malaria control with genetically manipulated insect vectors. *Science* **298**: 119–121.
- ANDERSON, W. W., 1989 Selection in natural and experimental populations of *Drosophila pseudoobscura*. *Genome* **31**: 239–245.
- ANDOLFATTO, P., F. DEPAULIS and A. NAVARRO, 2001 Inversion polymorphisms and nucleotide variability in *Drosophila*. *Genet. Res.* **77**: 1–8.
- BESANSKY, N. J., J. KRZYWINSKY, T. LEHMANN, F. SIMARD, M. KERN *et al.*, 2003 Semipermeable species boundaries between *Anopheles gambiae* and *Anopheles arabiensis*: evidence from multilocus DNA sequence variation. *Proc. Natl. Acad. Sci. USA* **100**: 10818–10823.
- BLANDIN, S., S. H. SHIAO, L. F. MOITA, C. J. JANSE, A. P. WATERS *et al.*, 2004 Complement-like protein TEPI is a determinant of vectorial capacity in the malaria vector *Anopheles gambiae*. *Cell* **116**: 661–670.
- BOCCOLINI, D., G. C. CARRARA, P. J. CANI and C. COSTANTINI, 2002 Preliminary data on *Anopheles funestus* chromosomal polymorphism in a peri-urban site of Western Angola. *Parassitologia* **44**: 22.
- CACERES, M., A. BARBADILLA and A. RUIZ, 1999 Recombination rate predicts inversion size in Diptera. *Genetics* **153**: 251–259.
- CATTERUCCIA, F., T. NOLAN, T. G. LOUKERIS, C. BLASS, C. SAVAKIS *et al.*, 2000 Stable germline transformation of the malaria mosquito *Anopheles stephensi*. *Nature* **405**: 959–962.
- COHUET, A., F. SIMARD, A. BERTHOMIEU, M. RAYMOND, D. FONTENILLE *et al.*, 2002 Isolation and characterization of microsatellite DNA markers in the malaria vector *Anopheles funestus*. *Mol. Ecol. Notes* **2**: 498–500.
- COHUET, A., F. SIMARD, J. C. TOTO, P. KENGNE, M. COETZEE *et al.*, 2003 Species identification within the *Anopheles funestus* group of malaria vectors in Cameroon and evidence for a new species. *Am. J. Trop. Med. Hyg.* **69**: 200–205.
- COLLINS, F. H., L. KAMAU, H. A. RANSON and J. M. VULULE, 2000 Molecular entomology and prospects for malaria control. *Bull. World Health Organ.* **78**: 1412–1423.
- COLUZZI, M., 1982 Spatial distribution of chromosomal inversions and speciation in Anopheline mosquitoes, pp. 143–153 in *Mechanisms of Speciation*, edited by C. BARIGOZZI. Alan R. Liss, New York.
- COLUZZI, M., A. SABATINI, V. PETRARCA and M. A. DI DECO, 1979 Chromosomal differentiation and adaptation to human environments in the *Anopheles gambiae* complex. *Trans. R. Soc. Trop. Med. Hyg.* **73**: 483–497.
- COLUZZI, M., V. PETRARCA and M. A. DI DECO, 1985 Chromosomal inversion intergradation in incipient speciation in *Anopheles gambiae*. *Boll. Zool.* **52**: 45–63.
- COLUZZI, M., A. SABATINI, A. DELLA TORRE, M. A. DI DECO and V. PETRARCA, 2002 A polytene chromosome analysis of the *Anopheles gambiae* species complex. *Science* **298**: 1415–1418.
- CORNEL, A. J., and F. H. COLLINS, 1996 PCR of the ribosomal DNA intergenic spacer regions as a method for identifying mosquitoes in the *Anopheles gambiae* complex. *Methods Mol. Biol.* **50**: 321–332.
- COSTANTINI, C., N. SAGNON, E. ILBOUDO-SANO, M. COLUZZI and D. BOCCOLINI, 1999 Chromosomal and bionomic heterogeneities suggest incipient speciation in *Anopheles funestus* from Burkina Faso. *Parassitologia* **41**: 595–611.
- DELLA TORRE, A., C. FANELLO, M. AKOGBETO, J. DOSSOU-YOVO, G. FAVIA *et al.*, 2001 Molecular evidence of incipient speciation within *Anopheles gambiae* s.s. in West Africa. *Insect Mol. Biol.* **10**: 9–18.
- DELLA TORRE, A., C. COSTANTINI, N. J. BESANSKY, A. CACCONE, V. PETRARCA *et al.*, 2002 Speciation within *Anopheles gambiae*—the glass is half full. *Science* **298**: 115–117.
- DIA, I., L. LOCHOUARN, D. BOCCOLINI, C. COSTANTINI and D. FONTENILLE, 2000a Spatial and temporal variations of the chromosomal inversion polymorphism of *Anopheles funestus* in Senegal. *Parasite* **7**: 179–184.
- DIA, I., D. BOCCOLINI, C. ANTONIO-NKONDJIO, C. COSTANTINI and D. FONTENILLE, 2000b Chromosomal inversion polymorphism of *Anopheles funestus* from forest villages of South Cameroon. *Parassitologia* **42**: 227–229.
- DOBZHANSKY, T., 1970 *Genetics of the Evolutionary Process*. Columbia University Press, New York.
- DONNELLY, M. J., F. SIMARD and T. LEHMANN, 2002 Evolutionary studies of malaria vectors. *Trends Parasitol.* **18**: 75–80.
- FONTENILLE, D., and F. SIMARD, 2004 Unravelling complexities in human malaria transmission dynamics in Africa through a comprehensive knowledge of vector populations. *Comp. Immunol. Microbiol. Infect. Dis.* **27**: 357–375.
- FONTENILLE, D., L. LOCHOUARN, N. DIAGNE, C. SOKHNA, J. J. LEMASSON *et al.*, 1997 High annual and seasonal variations in malaria

- transmission by anophelines and vector species composition in Dielmo, a holoendemic area in Senegal. *Am. J. Trop. Med. Hyg.* **56**: 247–253.
- GILLIES, M., and M. COETZEE, 1987 *A Supplement to the Anophelinae of Africa South of the Sahara*. The South African Institute for Medical Research, Johannesburg.
- GILLIES, M., and B. DE MEILLON, 1968 *The Anophelinae of Africa South of the Sahara (Ethiopian zoogeographical region)*. The South African Institute for Medical Research, Johannesburg.
- GOUDET, J., M. RAYMOND, T. DE MEEUS and F. ROUSSET, 1996 Testing differentiation in diploid populations. *Genetics* **144**: 1933–1940.
- GOULD, F., and P. SCHLIEKELMAN, 2004 Population genetics of autocidal control and strain replacement. *Annu. Rev. Entomol.* **49**: 193–217.
- GREENWOOD, B., and T. MUTABINGWA, 2002 Malaria in 2002. *Nature* **415**: 670–672.
- GROSSMAN, G. L., C. S. RAFFERTY, J. R. CLAYTON, T. K. STEVENS, O. MUKABAYIRE *et al.*, 2001 Germline transformation of the malaria vector, *Anopheles gambiae*, with the piggyBac transposable element. *Insect Mol. Biol.* **10**: 597–604.
- GUELBEOGO, W., D. BOCCOLINI, N. J. BESANSKY, N. F. SAGNON and C. COSTANTINI, 2002 Temporal variability in chromosomal inversion polymorphism of *Anopheles funestus* from two villages near Ouagadougou, Burkina Faso (West Africa). *Parassitologia* **44**: 86.
- HOLM, S., 1979 A simple sequential rejective multiple test procedure. *Scand. J. Stat.* **6**: 65–70.
- HUNT, R. H., 1973 A cytological technique for the study of *Anopheles gambiae* complex. *Parassitologia* **15**: 137–139.
- ITO, J., A. GHOSH, L. A. MOREIRA, E. A. WIMMER and M. JACOBS-LORENA, 2002 Transgenic anopheline mosquitoes impaired in transmission of a malaria parasite. *Nature* **417**: 452–455.
- JAMES, A. A., B. T. BEERNTSEN, L. CAPURRO MDE, C. J. COATES, J. COLEMAN *et al.*, 1999 Controlling malaria transmission with genetically-engineered, *Plasmodium*-resistant mosquitoes: milestones in a model system. *Parassitologia* **41**: 461–471.
- KAMAU, L., W. A. HAWLEY, T. LEHMANN, A. S. ORAGO, A. J. CORNEL *et al.*, 1998 Use of short tandem repeats for the analysis of genetic variability in sympatric populations of *Anopheles gambiae* and *Anopheles arabiensis*. *Heredity* **80**: 675–682.
- KAMAU, L., G. O. MUNYKENYENY, L. L. KOEKEMOER, R. H. HUNT and M. COETZEE, 2003 A survey of the *Anopheles funestus* (Diptera: Culicidae) group from 10 sites in Kenya with special emphasis on population genetic structure based on chromosomal inversion karyotypes. *J. Med. Entomol.* **40**: 664–671.
- KIDWELL, M. G., and J. M. C. RIBEIRO, 1992 Can transposable element be used to drive disease refractoriness genes into vector populations? *Parasitol. Today* **8**: 325.
- KING, M., 1993 *Species Evolution: The Role of Chromosomal Change*. Cambridge University Press, Cambridge, UK.
- KOEKEMOER, L. L., L. KAMAU, R. H. HUNT and M. COETZEE, 2002 A cocktail polymerase chain reaction assay to identify members of the *Anopheles funestus* (Diptera: Culicidae) group. *Am. J. Trop. Med. Hyg.* **66**: 804–811.
- KRIMBAS, C. B., and J. R. POWELL, 2000 Inversion polymorphisms in *Drosophila*, pp. 284–299 in *Evolutionary Genetics*, edited by R. S. SINGH and C. B. KRIMBAS. Cambridge University Press, Cambridge.
- LANZARO, G. C., and F. TRIPET, 2003 Gene flow among populations of *Anopheles gambiae*: a critical review, pp. 109–132 in *Ecological Aspects for Application of Genetically Modified Mosquitoes* (Wageningen Frontis Series, Vol. 2), edited by W. TAKKEN and T. W. SCOTT. Kluwer Academic Press, Dordrecht, The Netherlands.
- LANZARO, G. C., Y. T. TOURE, J. CARNAHAN, L. ZHENG, G. DOLO *et al.*, 1998 Complexities in the genetic structure of *Anopheles gambiae* populations in west Africa as revealed by microsatellite DNA analysis. *Proc. Natl. Acad. Sci. USA* **95**: 14260–14265.
- LOCHOUARN, L., I. DIA, D. BOCCOLINI, M. COLUZZI and D. FONTENILLE, 1998 Bionomical and cytogenetic heterogeneities of *Anopheles funestus* in Senegal. *Trans. R. Soc. Trop. Med. Hyg.* **92**: 607–612.
- MANGA, L., J. C. TOTO, G. LE GOFF and J. BRUNHES, 1997 The bionomics of *Anopheles funestus* and its role in malaria transmission in a forested area of southern Cameroon. *Trans. R. Soc. Trop. Med. Hyg.* **91**: 387–388.
- MAYR, E., 1963 *Animal Species and Evolution*. Harvard University Press, Cambridge, MA.
- NAVARRO, A., E. BETRAN, A. BARBADILLA and A. RUIZ, 1997 Recombination and gene flux caused by gene conversion and crossing over in inversion heterokaryotypes. *Genetics* **146**: 695–709.
- NOOR, M. A., K. L. GRAMS, L. A. BERTUCCI and J. REILAND, 2001 Chromosomal inversions and the reproductive isolation of species. *Proc. Natl. Acad. Sci. USA* **98**: 12084–12088.
- OLIVRY, J. C., 1986 *Fleuves et rivières du Cameroun*. Edition de l'ORS-TOM, Bondy, France.
- OSTA, M. A., G. K. CHRISTOPHIDES and F. C. KAFATOS, 2004 Effects of mosquito genes on *Plasmodium* development. *Science* **303**: 2030–2032.
- PETRARCA, V., A. D. NUGUD, A. ELKARIM, A. M. HARIDI, M. A. DI DECO *et al.*, 2000 Cytogenetics of the *Anopheles gambiae* complex in Sudan, with special reference to *An. arabiensis*: relationship with East and West African populations. *Med. Vet. Entomol.* **14**: 149–164.
- RAYMOND, M., and F. ROUSSET, 1995 GENEPOP, Version 1.2. A population genetics software for exact tests and ecumenicism. *J. Hered.* **26**: 248–249.
- REISEBERG, L. H., 2001 Chromosomal rearrangement and speciation. *TREE* **16**: 351–358.
- RIBEIRO, J. M., and M. G. KIDWELL, 1994 Transposable elements as population drive mechanisms: specification of critical parameter values. *J. Med. Entomol.* **31**: 10–16.
- ROUSSET, F., 1997 Genetic differentiation and estimation of gene flow from *F*-statistics under isolation by distance. *Genetics* **145**: 1219–1228.
- SHAHABUDDIN, M., S. COCIANCICH and H. ZIELER, 1998 The search for novel transmission-blocking targets in the mosquito midgut. *Parasitol. Today* **14**: 493–497.
- SHARAKHOV, I. V., M. V. SHARAKHOVA, C. M. MBOGO, L. L. KOEKEMOER and G. YAN, 2001 Linear and spatial organization of polytene chromosomes of the African malaria mosquito *Anopheles funestus*. *Genetics* **159**: 211–218.
- SHARAKHOV, I. V., O. BRAGINETS, O. G. GRUSHKO, A. COHUET, W. GUELBEOGO *et al.*, 2004 A microsatellite physical map of the African human malaria vector *Anopheles funestus*. *J. Hered.* **95**: 29–34.
- SINKINS, S. P., and S. L. O'NEILL, 2000 Wolbachia as a vehicle to modify insect populations, pp. 271–287 in *Insect Transgenesis: Methods and Applications*, edited by A. M. HANDLER and A. A. JAMES. CRC Press, Boca Raton, FL.
- SINKINS, S. P., B. J. HACKETT, C. COSTANTINI, J. VULULE, Y. Y. LING *et al.*, 2000 Isolation of polymorphic microsatellite loci from the malaria vector *Anopheles funestus*. *Mol. Ecol.* **9**: 490–492.
- STURTEVANT, A. H., and W. BEADLE, 1936 The relation of inversions in the X chromosome of *Drosophila melanogaster* to crossing over and disjunction. *Genetics* **21**: 544–604.
- TOURE, Y. T., V. PETRARCA, S. F. TRAORE, A. COULIBALY, H. M. MAIGA *et al.*, 1998 The distribution and inversion polymorphism of chromosomally recognized taxa of the *Anopheles gambiae* complex in Mali, West Africa. *Parassitologia* **40**: 477–511.
- TRIPET, F., G. DOLO and G. C. LANZARO, 2004 Multilevel analyses of genetic differentiation in *Anopheles gambiae* s.s. reveal patterns of gene flow important for malaria-fighting mosquito projects. *Genetics* **169**: 313–324.
- TURELLI, M., and A. A. HOFFMANN, 1999 Microbe-induced cytoplasmic incompatibility as a mechanism for introducing transgenes into arthropod populations. *Insect Mol. Biol.* **8**: 243–255.
- WANG, R., L. ZHENG, Y. T. TOURE, T. DANDEKAR and F. C. KAFATOS, 2001 When genetic distance matters: measuring genetic differentiation at microsatellite loci in whole-genome scans of recent and incipient mosquito species. *Proc. Natl. Acad. Sci. USA* **98**: 10769–10774.
- WEIR, B., and C. COCKERHAM, 1984 Estimating *F*-statistics for the analysis of population structure. *Evolution* **38**: 1358–1370.
- WORLD HEALTH ORGANIZATION, 1993 *A Global Strategy for Malaria Control*. World Health Organization, Geneva.
- WRIGHT, S., 1951 The genetical structure of populations. *Ann. Eugen.* **15**: 323–354.

